



# A CLOSER LOOK

CONTRACTOR / SERVICE BULLETIN

SEPTEMBER 1987

NUMBER 28

## DEHUMIDISTAT CIRCUITS FOR AIR CONDITIONING APPLICATIONS

### J10-809 WALL MOUNT DEHUMIDISTAT FOR LOW VOLTAGE (24 VAC or less) APPLICATIONS



#### Introduction

Dehumidistats, for residential and small office central air conditioning systems, may be wired in parallel or series with the indoor thermostat. This bulletin examines each arrangement.

The dehumidistat completes a circuit on the rise of relative humidity; the thermostat, on the rise of temperature.

The schematics in this article have been intentionally simplified to show the relationship of the dehumidistat to the thermostat. Refer to the equipment manufacturer's wiring diagram for the complete circuit of related components.

#### SERIES CIRCUIT SCHEMATIC

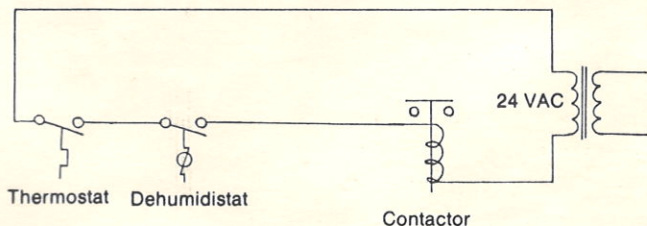

In the series circuit, both the temperature and relative humidity need to be at, or above the settings of the controls to activate the air conditioner.

#### PARALLEL CIRCUIT SCHEMATIC

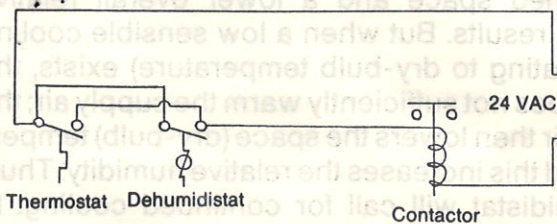

In the parallel circuit, the air conditioning can be activated by either temperature or relative humidity.

#### Series Circuit Considerations

A series circuit is frequently used in residences and buildings which are unoccupied. When unoccupied, the thermostat is set higher than when occupied and the dehumidistat is used to maintain a maximum relative humidity. In occupied buildings, the series arrangement takes advantage of the fact that if the indoor relative humidity is low, a higher temperature is comfortable. The higher thermostat setting saves cooling energy.

The series arrangement is fine as long as the space heat gain is such that the thermostat contacts remain closed. However, the dehumidistat cannot activate the system once the thermostat is satisfied and interrupts the circuit.

1529013-000

Copyright© 1987 Ranco Incorporated  
All rights reserved

## Parallel Circuit Considerations

A parallel circuit is advantageous when the indoor temperature can fall below the thermostat setting and the relative humidity rises. This condition can occur in the early morning when the indoor temperature has dropped due to the cool night, yet the relative humidity is high and a "clammy" feeling exists.

An important consideration with the parallel arrangement is the dehumidistat can operate the system regardless of indoor or outdoor temperature. Such operation can cause compressor damage if low ambient precautions are not taken.

Also, a condition can exist where the system will go into a continuous run. Moisture is removed as the return air contacts the evaporator (which is below the air's dew-point). While this process removes moisture, it also causes the air to leave the coil surface in a saturated condition (100% relative humidity). Normally, this cooled, high relative humidity air is warmed when it is mixed with the conditioned space and a lower overall relative humidity results. But when a low sensible cooling load (relating to dry-bulb temperature) exists, the space does not sufficiently warm the supply air; the supply air then lowers the space (dry-bulb) temperature and this increases the relative humidity. Thus, the humidistat will call for continued cooling. In short, the dry-bulb temperature drops faster than the relative humidity.

This situation relates to the sensible heat factor of the evaporator coil. The sensible heat factor is the ratio of the sensible load to the total cooling load. In many air conditioning applications, the sensible heat factor is such that the dry-bulb temperature will be reduced at a faster rate than the dew-point. As these two temperatures move closer together, the relative humidity increases.

One way to decrease the sensible heat factor is to reduce the air flow over the evaporator. This allows the air to remain in contact with the coil longer and more moisture is condensed out. This, although simply done by fan speed, can affect the heat transfer at the evaporator and result in coil icing and negative effects on the compressor. It can also affect the distribution patterns resulting from reduced air velocity in the air ducts.

Should it be desirable to wire the dehumidistat in parallel with the space thermostat, it may be wise to include a second space thermostat as a low limit. Also, a low ambient, compressor cut-out may be advisable.

### PARALLEL CIRCUIT, WITH LOW LIMIT

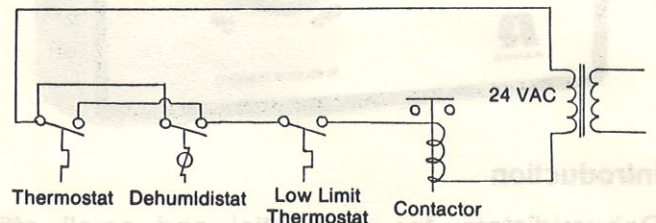

## RANCO Inc.

8115 U.S. Route 42 North  
P.O. Box 145  
Plain City, OH 43064

Bulk Rate  
U.S. Postage  
PAID  
Plain City, OH  
Permit No. 22

090-310031

# INSTRUCTION SHEET

Bulletin No. 1531016

## J10-0809 Dehumidistat Wall Mounting

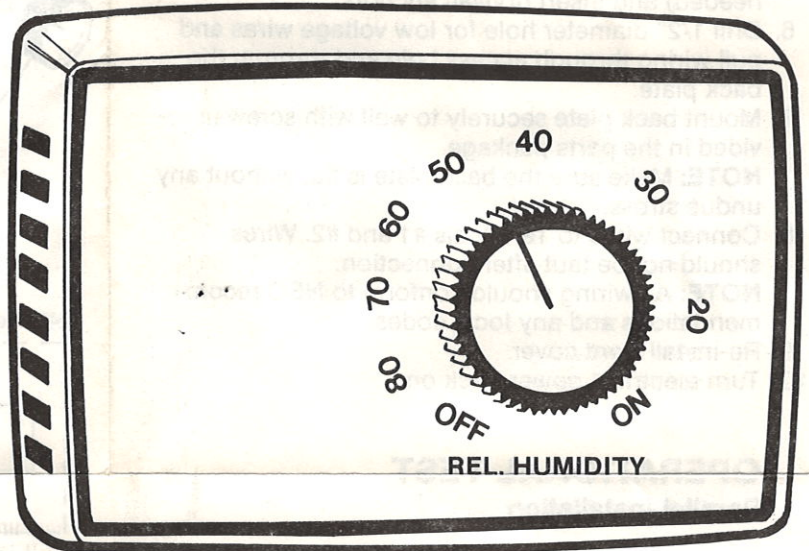

### APPLICATION

The J10-0809 is used to cycle an air conditioning system in an unoccupied home to help prevent mildew build-up associated with high humidity levels.

The J10-0809 is designed to be wall-mounted and can be wired in parallel or in series with any 24V thermostat.

### PARALLEL INSTALLATION

#### ADVANTAGES:

Desired humidity is always maintained regardless of ambient temperature.

#### DISADVANTAGES:

The air conditioning system could cycle on during low ambient temperatures.

**NOTE:** DO NOT USE parallel wiring if low temperature compressor protection is not present.

### SERIES INSTALLATION

#### ADVANTAGES:

Air conditioning system will not cycle on during low ambient temperature periods.

#### DISADVANTAGES:

Humidity levels may be higher than desired during low temperature periods.

## INSTALLATION INSTRUCTIONS

1. Disconnect electrical power.
  2. Determine dehumidistat location. This control should be mounted on an inside wall where normal air circulation. For most residential applications, locate the control adjacent to the existing wall thermostat for easy installation and wiring.
  3. Remove cover from back plate and punch wiring knockout on back plate.
  4. Place back plate on flat mounting surface and mark 2 mounting hole locations, and wire knockout hole.
  5. Drill 3/16" diameter holes for drywall anchors (if needed) and insert drywall anchors.
  6. Drill 1/2" diameter hole for low voltage wires and pull wiring through access hole and through the back plate.
  7. Mount back plate securely to wall with screws provided in the parts package.
- NOTE:** Make sure the back plate is flat without any undue stress.
8. Connect wires to Terminals #1 and #2. Wires should not be taut after connection.
- NOTE:** All wiring should conform to NEC recommendations and any local codes.
9. Re-install front cover.
  10. Turn electrical power back on.

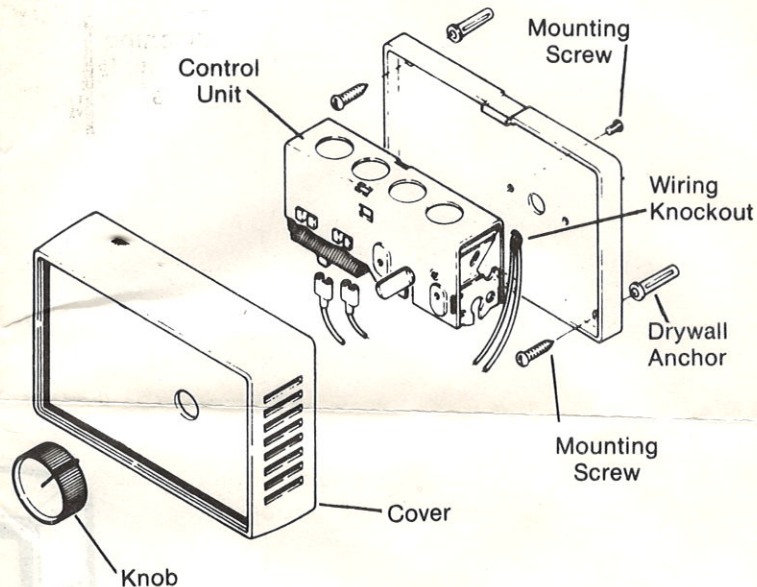

## WIRING DIAGRAMS

### Parallel Installation

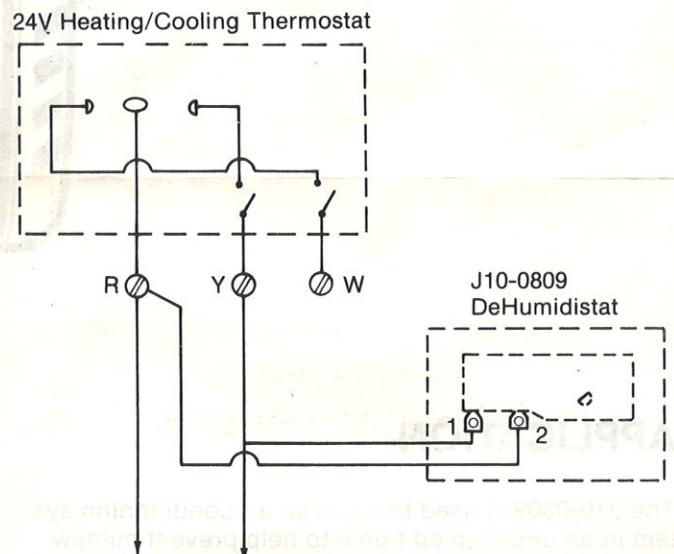

### Series Installation

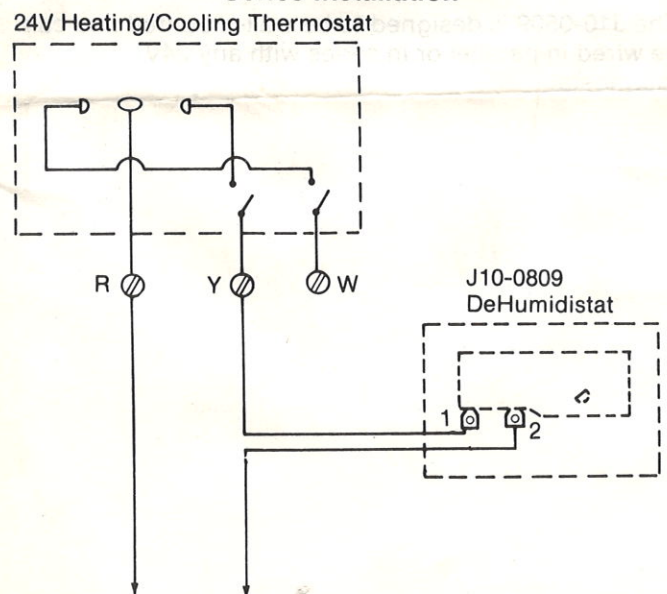

## OPERATIONAL TEST

### Parallel Installation

Turn the dehumidistat down until air conditioner turns on. Cycle at least 3 times to assure proper system function. Return control knob pointer to desired humidity setting.

## OPERATIONAL TEST

### Series Installation

Turn the thermostat to highest temperature setting. Turn dehumidifier control from lowest to highest setting. The air conditioning system should not start up. (If it does, wiring is incorrect.) Next, turn dehumidifier control to highest setting. Turn the thermostat from high to low temperature setting. Again, the system should not start up. Now, set thermostat on lowest temperature setting and dehumidifier control to lowest setting. System should now operate.

**NOTE:** The use of a sling psychrometer is recommended to determine relative humidity level.